

Esatto
by airvolution

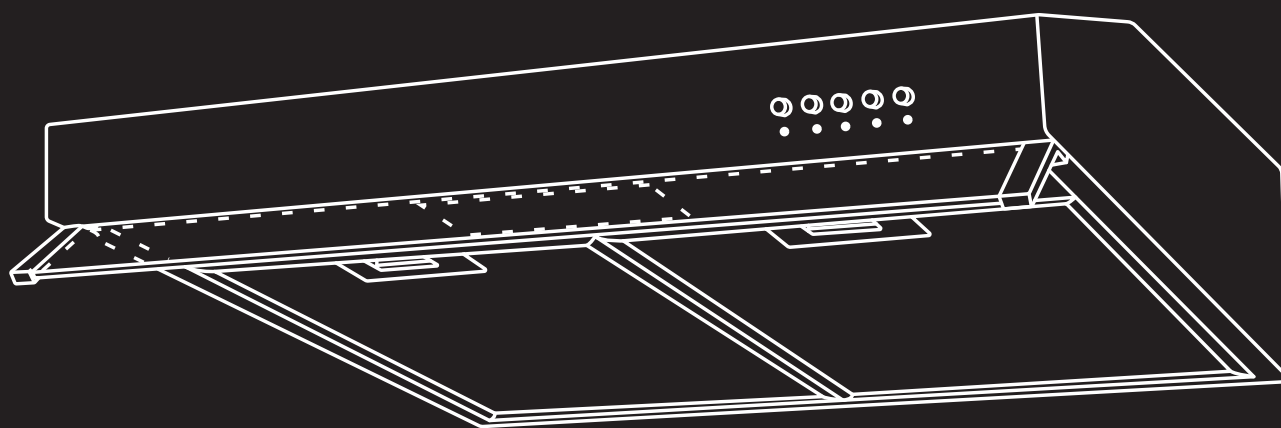

USER MANUAL

Fixed Rangehood
60cm

MODEL: EFH60W/EFH60S

A Residentia Group Initiative

Residentia Group

—
Head Office
165 Barkly Avenue
Burnley, Victoria
Australia 3121

—
ACN.
600 546 656

—
Online.
residentia.group

Dear Customer,

Congratulations on purchasing your new rangehood. The Esatto brand is proudly distributed within Australia by Residentia Group Pty Ltd.

Please refer to the warranty card at the rear of this manual for information regarding your product's parts and labour warranty, or visit us online at www.residentia.group

At Residentia Group, we are customer obsessed and our Support Team are there to ensure you get the most out of your appliance. Should you want to learn more about optional accessories (such as carbon filters) or most importantly taking care of your rangehood when cleaning, our Support Team are here to help.

You can use our online Support Centre at anytime by visiting <http://support.residentiagroup.com.au>, or you can contact us via telephone by dialling 1300 11 HELP (4357).

It is important that you read through the following use and care manual thoroughly to familiarise yourself with the installation and operation requirements of your appliance to ensure optimum performance.

Again, thank you for choosing an Esatto appliance and we look forward to being of service to you.

Kind Regards,
The Esatto & Residentia Teams

Postage.
PO Box 5177
Burnley, Victoria
Australia 3930

Telephone.
1300 11 4357
Email.
support@residentiagroup.com.au

CONTENTS

PAGE	SECTION
4	Safety Instructions
5	Your Rangehood
6	Operating Your Rangehood
7	Installation Instructions
9	Cleaning & Maintenance
10	Troubleshooting & Technical Data
11	Notes
12	Warranty Information
14	Purchase Details

SAFETY INSTRUCTIONS

This rangehood must only be installed in accordance with the instructions provided. Incorrect installation may cause harm to persons, damage property and void the product's warranty.

Important

Please ensure that you read the entire instructions before beginning the installation of your rangehood.

Warning

All electrical work must be done in accordance with local and national electrical codes as applicable and should be undertaken by licenced and qualified persons only.

- This rangehood is designed for domestic household use only.
- This appliance is not intended to be used by children, or persons with reduced physical, sensory or mental capabilities, or lack of experience and knowledge, unless they have been given supervision or instruction concerning the use of the rangehood by a person responsible for their safety.
- Young children should be supervised to ensure that they do not play with the appliance.
- You must read the instructions concerning the method and frequency of cleaning.

Important!

There is a risk of fire if cleaning isn't carried out in accordance with the instructions.

- Never flambé under the rangehood.
- Exhaust air must not be discharged into an existing flue which is used by other appliances for exhausting fumes.
- If the power supply cord of this rangehood is damaged in any way, it must only be replaced by Residentia Group or one of its authorised service agents. Please call the Residentia Support Team for further assistance.
- Your new rangehood is guaranteed against electrical or mechanical defects, subject to certain exclusions that are noted in the Warranty Terms and Conditions (at the rear of this user manual). The foregoing does not affect your statutory rights.
- The use of this rangehood for any other purpose or in any other environment, without the express agreement of Residentia Group, will invalidate any warranty or liability claim.
- No modifications to the appliance are permitted by Residentia Group.
- Repairs may only be carried out by authorised service agents.
- Cleaning of the rangehood should be carried out on a regular basis.

Unpacking

During transportation, protective packaging was used to protect the appliance against any damage. After unpacking, please dispose of all elements of packaging in a way that will not cause damage to the environment. All materials used for packaging the appliance are environmentally friendly; they are 100% recyclable and are marked with the appropriate symbol.

Caution! During unpacking, the packaging materials (polythene bags, polystyrene pieces, etc.) should be kept out of reach of children.

Disposal of the appliance

Old appliances should not simply be disposed of with normal household waste, but should be delivered to a collection and recycling centre for electric and electronic equipment. A symbol shown on the product, the instruction manual or the packaging shows that it is suitable for recycling.

Materials used inside the appliance are recyclable and are labelled with information concerning this. By recycling materials or other parts from used devices you are making a significant contribution to the protection of our environment.

Information on appropriate disposal centres for used devices can be provided by your local authority.

There shall be adequate ventilation of the room when the range hood is used at the same time as appliances burning gas or other fuels (not applicable to appliances that only discharge the air back into the room).

CAUTION: Accessible parts may become hot when used with cooking appliances.

YOUR RANGEHOODS

Specifications

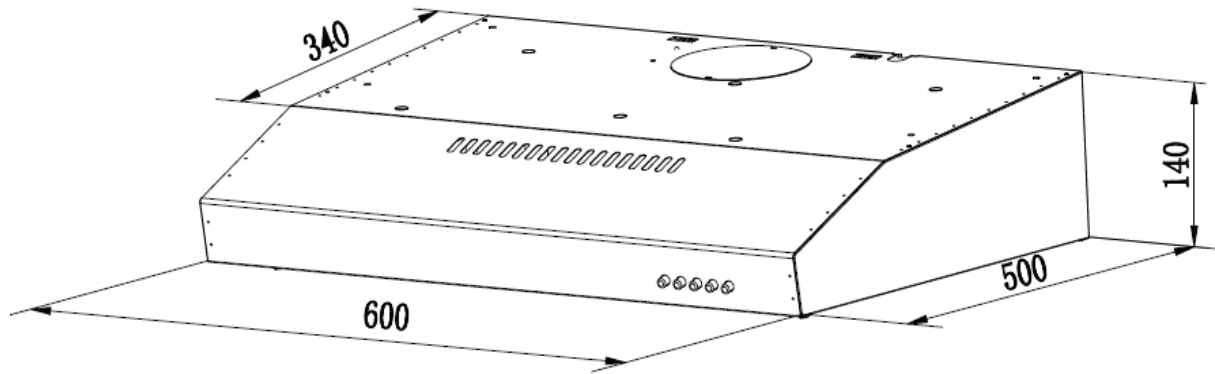

Model	Product dimensions (W,D,H mm)
EFH60W / EFH60S	600mm × 500mm × 140mm

Model	Extraction	Other features:
EFH60W / EFH60S	220m ³ /hr extraction	<ul style="list-style-type: none"> - 3 speed push button control - 1 × 2W LED lights - 2 × Aluminium filters

Rangehood components

Your Esatto Canopy Rangehood is supplied with:

- 1 × Rangehood
- 1 × Packet of fasteners and wall plugs
- 1 × 120mm Air outlet
- 1 × Outlet cover

Typical installation tools required

You'll most likely require the following tools/equipment (not supplied) for the installation of your rangehood.

- Electrical drill
- Tape Measure
- Screw-driver
- Spirit Level

If ducting your rangehood, you'll also most likely require:

- Jig saw
- Ladder
- Duct-tape
- Ducting

OPERATING YOUR RANGEHOOD

Controls

Your Esatto Canopy rangehood features push button controls with three speed levels of extraction.

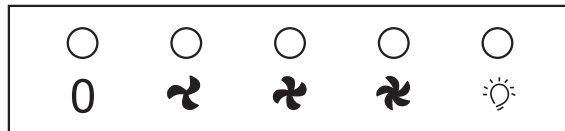

0

Off button

Used for turning off the fan.



Low Speed button

This speed is used for basic ventilation on the kitchen. It is suitable for simmering and cooking which does not make much steam.



Medium Speed button

This is ideal for standard cooking operation.



High Speed button

When a high density of smoke or steam is produced, use this speed for the highest effective ventilation.



Light button

Pressing this turns the lighting on or off.

*

Note: If Low / Medium / High speed buttons are press at the same time, the unit will only operate at the highest speed.

INSTALLATION INSTRUCTIONS

It's important to carefully read the following installation instructions before beginning the installation of your oven.

- Important installation safety**
- Always switch the power off prior to beginning the installation.
 - Stainless steel is very easily damaged during installation. Wherever possible, protect the rangehood with the cardboard box or plastic wrap during the installation.
 - For safety reasons, this Rangehood must be earthed.
 - A power point must be located within 1.5m of the power cord exit from the rangehood, and it should be always accessible to allow isolation from power during cleaning or maintenance.
 - A 150mm round ducting adapter is supplied, however all other ducting accessories are not.
 - All ducting must comply with building codes and local requirements.
 - If you are re-circulating the air, rather than ducting, please ensure that the side outlet grilles are not obstructed in any way as this will effect the efficiency of the rangehood.
 - Ensure that the rangehood is mounted in a level position, both horizontally and vertically. This is essential to ensure the rangehood operates correctly and prevents grease build up at one end.

Ducting options

Before beginning the installation of your rangehood, the method of ducting should be considered and selected. The guide below illustrates the various ducting options.

Note: This rangehood can be operated in recirculation mode where required, although Esatto recommends to duct wherever possible.



1. Into your ceiling cavity and then vented through your eaves.



2. Straight up and through your tiled or metal roof.



INSTALLATION INSTRUCTIONS CONTINUED

Installation heights

- Over gas and electric cookers, Esatto recommends our rangehoods to be mounted at a height of between 600-800mm above the cooking surface.
- Electric cooktops must have a minimum height of 600mm from the underside of the rangehood to the cooktop face.
- Gas cooktops must have a minimum of 650mm from the burner to the underside of the rangehood.
- It is not recommended to install the rangehood outside or over open flame grillers or barbecues.

Installing the rangehood

Way one:

- To install onto the wall drill 2 holes of $\varnothing 8$ mm on a suitable place according with the centre distance of hole in the back of the cooker hood. Insert the nut into the holes. Insert the screws into the nuts and tight. Put the cooker hood onto the tighten screws.

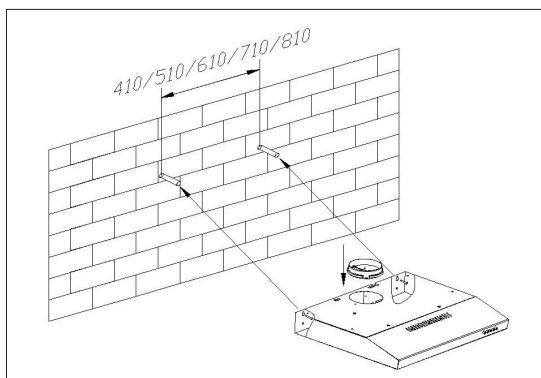

- Fix the cooker hood with safety screw. The two safety vents are positioned on the back casing, with diameter of 6mm. Put the one way valve onto the cooker hood.

Way two:

- Drill 4 holes of 6mm diameter at the bottom of the hanging cupboard. Put the one way valve on the cooker hood, then install the cooker hood on the bottom of the hanging cupboard, tighten the hood with enclosed 4 screws.

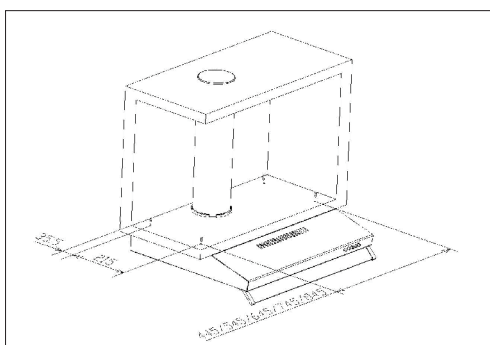

- The extensible pipe are optional accessory, not supplied.
- Take off protection film before installation.
- There are 2 methods for ventilation , including ' horizontal ventilation' and ' vertical ventilation'. Please pay attention to the ventilation method when installation. Vertical ventilation: See Pic A, please use tool take out the round cover before using, and the air can be vented from top. horizontal ventilation: See Pic B, please use tool take out the rectangular cover before using, and the air can be vented from back. The rectangular air outlet for horizontal ventilation is not supplied.

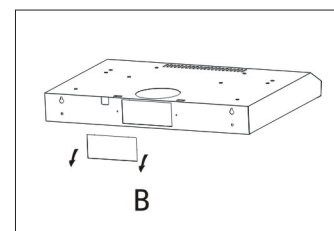
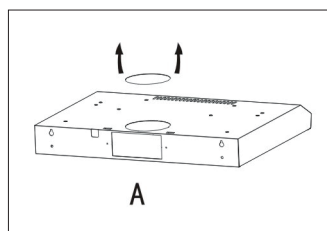

Air ventilation setting

- Outdoor exhausting: Turn the adjuster to outdoor position, install the outlet, turn on the cooker hood, then the air will be vented from the outside outlet.

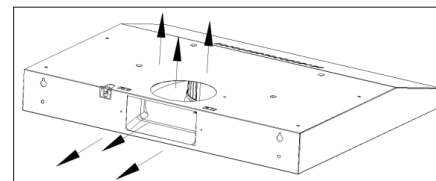
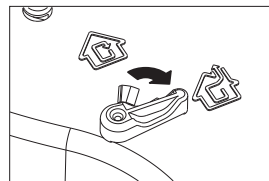

- Recycling: the recycling mode with carbon filter ,Turn the adjuster to indoor position, install the outlet cover, turn on the cooker hood, then the air can be vented from the inside outlet.

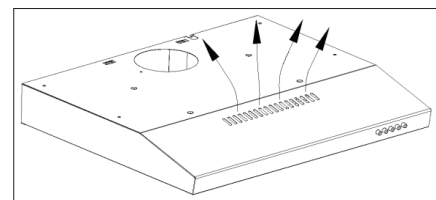
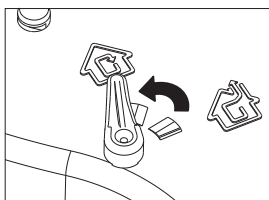

- Note: The charcoal filter is mounted on the back of the grill and must be changed once three month. Warning: the charcoal cannot be washed or recycled. It should be changed at most after 120 hours using. The carbon filter shouldn't be exposed to heat.

CLEANING & MAINTENANCE

By ensuring proper cleaning and maintenance of your Esatto rangehood, you can ensure that it will have a long and fault free operation.

Cleaning the grease filters

Keeping this filter clean will keep the rangehood extraction performance at an optimum. Please strictly follow the guidelines below.

- The grease filter mesh is made of high-density stainless steel. Please ensure you never use a corrosive detergent during cleaning.
- Method 1: Put the mesh into 40-50°C clean water with a small amount of regular dishwashing liquid, and soak for 2-3 mins. Wear gloves and clean with a soft brush. Please do not apply too much pressure, as the mesh is delicate and will damage easy.
- **Warning!** Your rangehood grease filters can not be washed in your dishwasher, or the protection coating would be cleaned away.

Cleaning the cooker hood

To protect the main body of your rangehood from corrosion or stains, the cooker hood should be cleaned with hot water with a non-corrosive detergent every two months. For stubborn stains or marks, you can try using a specific stainless steel cleaner available from most supermarkets.

Warning!

Please do not use a corrosive detergent, or abrasive clothes, as it will damage the body.

- Keep the motor and other spare parts free from water, as this will cause damage to the appliance.
- Before cleaning the rangehood, always switch the power off at the outlet and unplug the rangehood.
- If your rangehood has a damaged plug or cord, please ensure your rangehood remains unplugged and contact the Residentia Support team for further assistance. Any electrical work should only be completed by a suitably licenced and authorised person.
- If you're using a carbon filter, it should never be exposed to heat.

TROUBLESHOOTING & TECHNICAL DATA

Operation in case of emergency

In the event of an emergency you should:

- Switch off all rangehood controls.
- Switch the rangehood off at the power outlet and immediately unplug.
- Call the Residentia Support Team on 1300 11 HELP (4357).

Some minor faults can be fixed by referring to the instructions given in the Troubleshooting section below. There is also a self-help section online at <https://residentia.zendesk.com/>

Important! If your appliance appears to be operating incorrectly, then you should disconnect it from your electrical supply and then contact the Residentia Group Support team on 1300 11 HELP (4357).

Warning! Do not attempt to repair the rangehood yourself.

Please note that if an engineer is asked to attend whilst the product is under warranty and finds that the problem is not the result of an appliance fault, then you may be liable for the cost of the call out charge.

The appliance must be accessible for the engineer to perform any necessary repair. If your appliance is installed in such a way that an engineer is concerned that damage will be caused to the appliance or your kitchen, then they will not complete a repair. This includes situations where the rangehood has been tiled in or sealed in with a sealant.

Please refer to the conditions of that appear on the warranty card at the rear of this user manual.

Fault:	Common Cause:	Common Solutions:
The lights work, however the motor does not work	The motor is blocked or jammed or the capacitor is damaged.	Call the Residentia Support team for further guidance.
	The capacitor damaged	Call the Residentia Support team for further guidance.
Neither the lights or the motor works	Beside the above mentioned, check the following:	
	Light globes are damaged or blown	Replace the light globe(s)
	The power cord is loose.	Ensure that the rangehood is correctly plugged in and the power outlet is switched on.
The rangehood is vibrating against the wall	The rangehood canopy is not fixed to the wall correctly.	Ensure that the internal safety screws have been used and tight.
Insufficient suction	The distance between the rangehood and your cooktop is too great.	Have your installer re-adjust the installation position, ensuring that the minimum distances are observed as per the building code.

Technical data

Electrical details

Rated Voltage: AC 220 – 240 V, 50Hz

WARRANTY

Warranty terms and conditions Cooking appliances (rangehoods)

This document sets out the terms and conditions of the product warranties for Residentia Group Appliances. It is an important document. Please keep it with your proof of purchase documents in a safe place for future reference should you require service for your Appliance.

1. In this warranty
 - (a) 'acceptable quality' as referred to in clause 10 of this warranty has the same meaning referred to in the ACL;
 - (b) 'ACL' means Trade Practices Amendment (Australian Consumer Law) Act (No.2) 2010;
 - (c) 'Appliance' means any Residentia Group product purchased by you accompanied by this document;
 - (d) 'ASR' means Residentia Group authorised service representative;
 - (e) 'Residentia Group' means Residentia Group Pty Ltd of 118 Campbell St Collingwood Victoria 3083, ACN 600 546 656 in respect of Appliances purchased in Australia;
 - (f) 'major failure' as referred to in clause 10 of this warranty has the same meaning referred to in the ACL and includes a situation when an Appliance cannot be repaired or it is uneconomic for Residentia Group, at its discretion, to repair an Appliance during the Warranty Period;
 - (g) 'Warranty Period' means:
 - (i) where the Appliance is used for personal, domestic or household use (i.e. normal single family use) as set out in the instruction manual, the Appliance is warranted against manufacturing defects for 24 months, following the date of original purchase of the Appliance;
 - (h) 'you' means the purchaser of the Appliance not having purchased the Appliance for re-sale, and 'your' has a corresponding meaning.
2. This warranty only applies to Appliances purchased and used in Australia and is in addition to (and does not exclude, restrict, or modify in any way) any non-excludable statutory warranties in Australia.
3. During the Warranty Period Residentia Group or its ASR will, at no extra charge if your Appliance is readily accessible for service, without special equipment and subject to these terms and conditions, repair or replace any parts which it considers to be defective. Residentia Group or its ASR may use remanufactured parts to repair your Appliance. You agree that any replaced Appliances or parts become the property of Residentia Group. This warranty does not apply to light globes, batteries, filters or similar perishable parts.
4. Parts and Appliances not supplied by Residentia Group are not covered by this warranty.

WARRANTY CONTINUED

5. You will bear the cost of transportation, travel and delivery of the Appliance to and from Residentia Group or its ASR. If you reside outside of the service area, you will bear the cost of:
 - (a) travel of an authorised representative;
 - (b) transportation and delivery of the Appliance to and from Residentia Group or its ASR, in all instances, unless the Appliance is transported by Residentia Group or its ASR, the Appliance is transported at the owner's cost and risk while in transit to and from Residentia Group or its ASR.
6. Proof of purchase is required before you can make a claim under this warranty.
7. You may not make a claim under this warranty unless the defect claimed is due to faulty or defective parts or workmanship. Residentia Group is not liable in the following situations (which are not exhaustive):
 - (a) the Appliance is damaged by:
 - (i) accident
 - (ii) misuse or abuse, including failure to properly maintain or service
 - (iii) normal wear and tear
 - (iv) power surges, electrical storm damage or incorrect power supply
 - (v) incomplete or improper installation
 - (vi) incorrect, improper or inappropriate operation
 - (vii) insect or vermin infestation
 - (viii) failure to comply with any additional instructions supplied with the Appliance;
 - (b) the Appliance is modified without authority from Residentia Group in writing;
 - (c) the Appliance's serial number or warranty seal has been removed or defaced;
 - (d) the Appliance was serviced or repaired by anyone other than Residentia Group, an authorised repairer or ASR.
8. This warranty, the contract to which it relates and the relationship between you and Residentia Group are governed by the law applicable where the Appliance was purchased.
9. To the extent permitted by law, Residentia Group excludes all warranties and liabilities (other than as contained in this document) including liability for any loss or damage whether direct or indirect arising from your purchase, use or non use of the Appliance.
10. For Appliances and services provided by Residentia Group in Australia, the Appliances come with a guarantee by Residentia Group that cannot be excluded under the Australian Consumer Law. You are entitled to a replacement or refund for a major failure and for compensation for any other reasonably foreseeable loss or damage. You are also entitled to have the Appliance repaired or replaced if the Appliance fails to be of acceptable quality and the failure does not amount to a major failure. The benefits to you given by this warranty are in addition to your other rights and remedies under a law in relation to the Appliances or services to which the warranty relates.
11. At all times during the Warranty Period, Residentia Group shall, at its discretion, determine whether repair, replacement or refund will apply if an Appliance has a valid warranty claim applicable to it.
12. To enquire about claiming under this warranty, please follow these steps:
 - (a) carefully check the operating instructions, user manual and the terms of this warranty;
 - (b) have the model and serial number of the Appliance available;
 - (c) have the proof of purchase (e.g. an invoice) available;
 - (d) telephone the numbers shown below.
13. You accept that if you make a warranty claim, Residentia Group and its ASR may exchange information in relation to you to enable Residentia Group to meet its obligations under this warranty.

IMPORTANT

Before calling for service, please ensure that the steps in point 12 have been followed.

The Australian Consumer Law requires the inclusion of the following statement with this warranty:

Telephone contacts

- ▶ Service: Please call 1300 11 HELP (4357)
- ▶ Spare Parts: Please call 1300 11 SPARE (7727)

Our goods come with guarantees that cannot be excluded under the Australian Consumer Law. You are entitled to a replacement or refund for a major failure and for compensation for any other reasonably foreseeable loss or damage. You are also entitled to have the goods repaired or replaced if the goods fail to be of acceptable quality and the failure does not amount to a major failure.

PURCHASE DETAILS

For your records, please record details of your purchase below and staple your receipt on the opposite page.

Store details

Store name | _____

Address | _____

Telephone | _____

Purchase date | _____

Product details

Model no. | _____

Serial no.* | _____

* Note. Your serial number can be found on the inside of the rangehood, underneath the grease filter.

RECEIPT



Esatto by airvolution

Visit Us Online
www.esatto.house
www.airvolution.space

VERSION
NUMBER

1.3



E2447